



SHI PRODUCT PASSPORT

Find products. Certify buildings.

SHI Product Passport No.:

15461-10-1001

**S6o Flex Life Top, S1oo life, Kernsockelleiste 6o/8o,
D6o life TOP, C6o life TOP**

Product group: Skirting boards

Döllken Profiles

Döllken Profiles GmbH
Industriestraße 1
59199 Bönen



Product qualities:

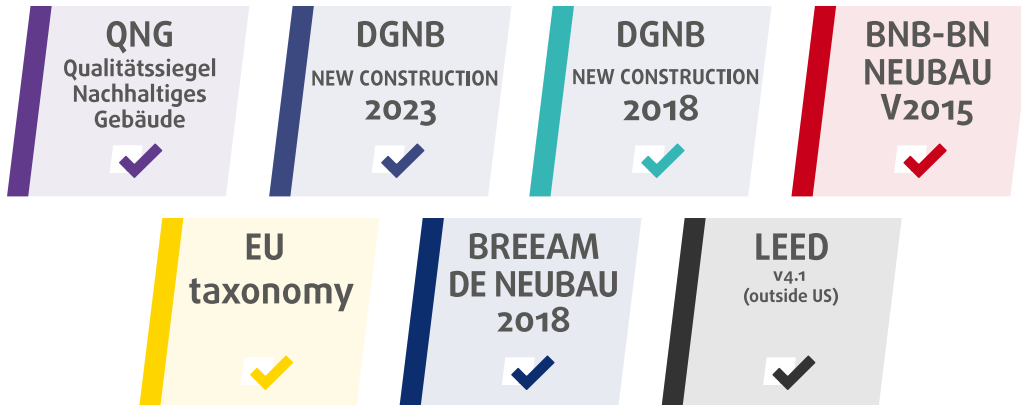

Köttner

Helmut Köttner
Scientific Director

Freiburg, 20 April 2026



Product:







S6o Flex Life Top, S10o life, Kernsockelleiste 6o/8o, D6o life TOP,
C6o life TOP

SHI Product Passport no.:

15461-10-1001

Döllken Profiles

Contents

 QNG - Qualitätssiegel Nachhaltiges Gebäude	1
 DGNB New Construction 2023	2
 DGNB New Construction 2018	3
 BNB-BN Neubau V2015	4
 EU taxonomy	5
 BREEAM DE Neubau 2018	6
 LEED v4.1	7
Product labels	8
Legal notices	9
Technical data sheet/attachments	10

The SHI Database is the first and only database for construction products whose comprehensive processes and data accuracy are regularly verified by the independent auditing company SGS-TÜV Saar





Product:

S60 Flex Life Top, S100 life, Kernsockelleiste 60/80, D60 life TOP,
C60 life TOP

SHI Product Passport no.:

15461-10-1001

Döllken Profiles

QNG - Qualitätssiegel Nachhaltiges Gebäude

The Qualitätssiegel Nachhaltiges Gebäude (Quality Seal for Sustainable Buildings), developed by the German Federal Ministry for Housing, Urban Development and Building (BMWSB), defines requirements for the ecological, socio-cultural, and economic quality of buildings. The Sentinel Holding Institut evaluates construction products in accordance with QNG requirements for certification and awards the QNG ready label. Compliance with the QNG standard is a prerequisite for eligibility for the KfW funding programme. For certain product groups, the QNG currently has no specific requirements defined. Although classified as not assessment-relevant, these products remain suitable for QNG-certified projects.

Criteria	Pos. / product group	Considered substances	QNG assessment
3.1.3 Schadstoffvermeidung in Baumaterialien			QNG ready - Not relevant for assessment



Product:

**S60 Flex Life Top, S100 life, Kernsockelleiste 60/80, D60 life TOP,
C60 life TOP**

SHI Product Passport no.:

15461-10-1001

Döllken Profiles

DGNB New Construction 2023

The DGNB System (German Sustainable Building Council) assesses the sustainability of various types of buildings. It can be applied to both large-scale private and commercial projects as well as smaller residential buildings. The 2023 version sets high standards for ecological, economic, socio-cultural, and functional aspects throughout the entire life cycle of a building.

Criteria	Assessment
ENV1.1 Climate action and energy (*)	May positively contribute to the overall building score

Criteria	Assessment
SOC1.2 Indoor air quality (*)	May positively contribute to the overall building score

Verification: Sockelleisten sind mit Blauem Engel und Greenguard zertifiziert

Criteria	No. / Relevant building components / construction materials / surfaces	Considered substances / aspects	Quality level
ENV 1.2 Local environmental impact, 03.05.2024 (3rd edition)			Not relevant for assessment

Criteria	No. / Relevant building components / construction materials / surfaces	Considered substances / aspects	Quality level
ENV 1.2 Local environmental impact, 29.05.2025 (4th edition)			Not relevant for assessment



Product:

S6o Flex Life Top, S10o life, Kernsockelleiste 6o/8o, D6o life TOP,
C6o life TOP

SHI Product Passport no.:

15461-10-1001

Döllken Profiles

DGNB New Construction 2018

The DGNB System (German Sustainable Building Council) assesses the sustainability of various types of buildings. It can be applied to both large-scale private and commercial projects as well as smaller residential buildings.

Criteria	No. / Relevant building components / construction materials / surfaces	Considered substances / aspects	Quality level
ENV 1.2 Local environmental impact			Not relevant for assessment



Product:

S60 Flex Life Top, S100 life, Kernsockelleiste 60/80, D60 life TOP,
C60 life TOP

SHI Product Passport no.:

15461-10-1001

Döllken Profiles

BNB-BN Neubau V2015

The Bewertungssystem Nachhaltiges Bauen (Assessment System for Sustainable Building) is a tool for evaluating public office and administrative buildings, educational facilities, laboratory buildings, and outdoor areas in Germany. The BNB was developed by the former Federal Ministry for the Environment, Nature Conservation, Building and Nuclear Safety (BMUB) and is now overseen by the Federal Ministry for Housing, Urban Development and Building (BMWSB).

Criteria	Pos. / product type	Considered substance group	Quality level
1.1.6 Risiken für die lokale Umwelt			Not relevant for assessment



Product:

S6o Flex Life Top, S10o life, Kernsockelleiste 6o/8o, D6o life TOP,
C6o life TOP

SHI Product Passport no.:

15461-10-1001

Döllken Profiles

EU taxonomy

The EU Taxonomy classifies economic activities and products according to their environmental impact. At the product level, the EU regulation defines clear requirements for harmful substances, formaldehyde and volatile organic compounds (VOCs). The Sentinel Holding Institut GmbH labels qualified products that meet this standard.

Criteria	Product type	Considered substances	Assessment
DNSH - Pollution prevention and control		Substances according to Annex C	EU taxonomy compliant
Verification: Herstellererklärung vom 10.04.2026			



Product:

S60 Flex Life Top, S100 life, Kernsockelleiste 60/80, D60 life TOP,
C60 life TOP

SHI Product Passport no.:

15461-10-1001

Döllken Profiles

BREEAM DE Neubau 2018

BREEAM (Building Research Establishment Environmental Assessment Methodology) is a UK-based building assessment system that evaluates the sustainability of new constructions, refurbishments, and conversions. Developed by the Building Research Establishment (BRE), the system aims to assess and improve the environmental, economic, and social performance of buildings.

Criteria	Product category	Considered substances	Quality level
Hea 02 Indoor Air Quality			Not relevant for assessment



Product:

**S60 Flex Life Top, S100 life, Kernsockelleiste 60/80, D60 life TOP,
C60 life TOP**

SHI Product Passport no.:

15461-10-1001

Döllken Profiles

LEED v4.1

LEED (Leadership in Energy and Environmental Design) is an internationally recognised building certification system developed by the U.S. Green Building Council. It is one of the most widely used sustainability standards for buildings worldwide and is particularly applied in internationally oriented projects. LEED assesses buildings holistically across categories such as energy efficiency, resource conservation, material selection, indoor environmental quality and site sustainability. Depending on the number of points achieved, projects are awarded one of the certification levels: LEED Certified, Silver, Gold or Platinum.

Criteria	Product category	Considered substances	Assessment
EQ Credit: Low-Emitting Materials			Not relevant for assessment



Product:

S60 Flex Life Top, S100 life, Kernsockelleiste 60/80, D60 life TOP,
C60 life TOP

SHI Product Passport no.:

15461-10-1001

Döllken Profiles

Product labels

In the construction industry, high-quality materials are crucial for a building's indoor air quality and sustainability. Product labels and certificates offer guidance to meet these requirements. However, the evaluation criteria of these labels vary, and it is important to carefully assess them to ensure products align with the specific needs of a construction project.



Products bearing the Sentinel Holding Institute QNG-ready seal are suitable for projects aiming to achieve the "Qualitätssiegel Nachhaltiges Gebäude" (Quality Seal for Sustainable Buildings). QNG-ready products meet the requirements of QNG Appendix Document 3.1.3, "Avoidance of Harmful Substances in Building Materials." The KfW loan program Climate-Friendly New Construction with QNG may allow for additional funding.



Product:

S6o Flex Life Top, S1oo life, Kernsockelleiste 6o/8o, D6o life TOP,
C6o life TOP

SHI Product Passport no.:

15461-10-1001

Döllken Profiles

Legal notices

(*) These criteria apply to the construction project as a whole. While individual products can positively contribute to the overall building score through proper planning, the evaluation is always conducted at the building level. The information was provided entirely by the manufacturer.

Find our criteria here: <https://www.sentinel-holding.eu/de/Themenwelten/Pr%C3%BCfverfahren/kriterien%20f%C3%BCr%20Produkte>

The SHI Database is the first and only database for construction products whose comprehensive processes and data accuracy are regularly verified by the independent auditing company SGS-TÜV Saar

Publisher

Sentinel Holding Institut GmbH
Bötzing Str. 38
79111 Freiburg im Breisgau
Germany
Tel.: +49 761 590 481-70
info@sentinel-holding.eu
www.sentinel-holding.eu

Technisches Datenblatt S 60 flex life Top

Kernsockelleiste für
alle Bodenbelagsarten

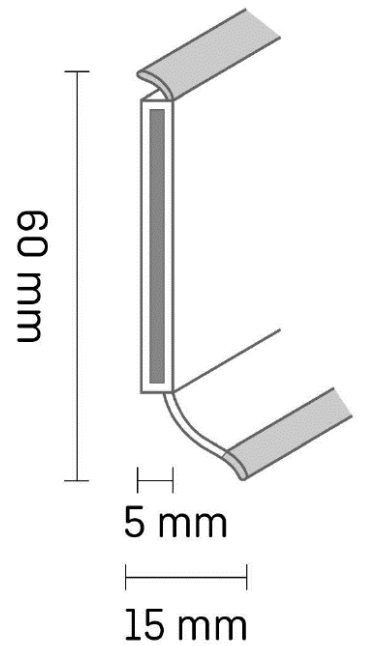

Döllken Profiles

SURTECO GROUP

Verarbeitungsempfehlung



Döllken
Stanze



Döllken
Schmelzkleber



Döllken
Sockelleisten-
schere



Klebeband
UZIN



Auslink-
zange

Stanzbar – Für die Bildung der Innen- und Außenecken sind keine zusätzlichen Formteile notwendig – lediglich die Döllken Stanze. Dieses Gerät ist speziell für die Eckenbildung an Döllken Profilen Kernsockelleisten entwickelt worden und mit ihrer Hilfe kann der Verarbeiter auf einfache und effiziente Art und Weise akkurate Innenecken sowie fugenlos umlaufende Außenecken bilden. Die geschlossene Oberfläche, welche beim Stanzen der Außenecke erzeugt wird, verhindert zusätzlich, dass Feuchtigkeit in den Eckbereich eindringen kann.

Befestigung:

Kleben – Für die schnelle, saubere und sichere Befestigung der Leisten empfehlen wir das Döllken Profilen Heißschmelzklebe-System einzusetzen.



Verarbeitungsvideos und weitere hilfreiche Tipps und Tricks vom Profi finden Sie auf  YouTube

Für die Bildung der Innen- und Außenecken sind keine zusätzlichen Formteile notwendig.

Die weichen, flexiblen Wand- und Bodenlippen passen sich den Unebenheiten der jeweiligen Oberfläche an. So werden Schattenfugen verhindert und Nacharbeiten mit Silikon oder Acryl entfallen.

Produktvorteile

- Elastische Weichlippen zur Wand und zum Boden
- Einfache Montage
- widerstandsfähig gegenüber Feuchtigkeit, Schmutz und Schlägen
- Robuste Oberfläche
- Mit der Stanze fugenlose Außen- und passgenaue Innenecken
- Kein Zubehör erforderlich
- Kein Dreck und Lärm beim Zuschneiden der Leiste

Material

- HDF-Kern, ummantelt mit dem chlorfreien Polyblend auf Basis PP/TPE
- mit formschlüssigen Weichlippen aus TPE
- Die Kernsockelleisten bestehen aus FSC-zertifizierten Holzwerkstoffen, ummantelt mit Polypropylen und mit formschlüssigen Applikationen aus TPE. Diese Kunststoffe sind frei von Halogene, u.a. Chlor, Weichmachern und Silikonen.

Zertifikate

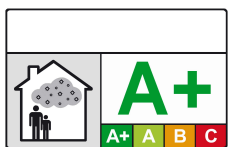

www.blauer-engel.de/uz176

Lieferform

Verpackungsgröße:
1 VE = 20 x 5,15m

Verpackung: Kartonagen-Verpackung mit Klebeband verschlossen und VE Papieretiketten mit Artikelbeschriftung versehen.

Lagerung

Eben, Trocken und witterungsgeschützt lagern. Die Profile müssen 24 Stunden vor der Verarbeitung flachliegend im Objekt aklimatisiert werden.

Brandverhalten

DIN EN 13501-1 KLASSE E

Reinigung und Pflege

Reinigen Sie die leicht verschmutzte Oberfläche mit einem feuchten Tuch. Verwenden Sie für stärkere Verschmutzungen ein handelsübliches Haushaltsreinigungsmittel und beachten Sie die Angaben der Dosieranleitungen des jeweiligen Herstellers. Sie sollten Reinigungsmittel mit abrasiven, sauren oder bleichenden Inhaltsstoffen vermeiden. Verwenden Sie keine scheuernden Haushaltsschwämme. Siehe auch separate Reinigungs- und Pflegeanleitung.

Untergrund

Vor der Befestigung der Leiste ist die Wand auf Ihre Eignung für die jeweilige Befestigungsart zu prüfen. Weichmacherhaltige Untergründe sind grundsätzlich bei Verklebung auf Verklebbarkeit zu prüfen. Es gelten die gleichen Untergrundprüfungen, wie diese auch zur Verlegung von Bodenbelägen in der DIN 18365 „Bodenbelagsarbeiten“ vorgegeben werden. Diesbezüglich stellen die Prüfmaßnahmen am Untergrund folgende besondere Schwerpunkte dar:

- Ebenheit und Winkligkeit des Untergrundes
- keine Feuchtigkeit des Untergrundes
- genügend feste, staubfreie-, keine porösen oder rauen Oberflächen
- keine Risse im Untergrund
- keine verunreinigten Oberflächen des Untergrundes, z.B. durch Öl, Wachs, Lacke, Farbreste etc.
- geeignete Temperatur des Untergrundes
- geeignetes Wohn- Raumklima.

Entsorgung

20 01 39 Kunststoffe Empfehlung: Kann unter Beachtung der notwendigen technischen Vorschriften nach Rücksprache mit dem Entsorger und der zuständigen Behörde mit Hausmüll zusammen abgelagert oder mit Hausmüll zusammen verbrannt werden.

15 01 01 Verpackungen aus Papier und Pappe: Vollständig entleerte Verpackungen können einer Verwertung zugeführt werden.

Farben

Sonderfarben auf
Anfrage möglich!

Alle aktuellen Farben finden Sie online auf unserer Website oder in der Döllken Profiles App.

Einfach mit dem Smartphone
scannen und Dekore bzw.
Farben checken:





Die jeweils aktuelle Fassung dieses Datenblatts finden Sie auf unserer Website unter doellken-profiles.com

Diese Angaben und technischen Informationen sind auf Basis unserer Erfahrungen und dem neusten Stand der Technik erstellt worden. Sie können jedoch nur allgemeine Hinweise ohne Eigenschaftszusicherung sein, da wir keinen Einfluss auf die Baustellenbedingungen, auf die Ausführung der Arbeiten und die Verarbeitung haben. Die einschlägigen Empfehlungen, Richtlinien sowie DIN-Vorschriften sowie Verarbeitungsempfehlungen der mit verwendeten Materialien sind zu beachten. Im Zweifelsfall Eigenversuche durchführen oder anwendungstechnische Beratung einholen. Mit dem Erscheinen dieses Produktdatenblattes verlieren alle vorausgegangenen Produktdatenblätter ihre Gültigkeit.

Döllken Profiles GmbH
Industriestraße 1
59199 Bönen
T: +49 3643 4170 711
F: +49 3643 4170 330
info@doellken-profiles.com
www.doellken-profiles.com
Follow us on   

C 60 life TOP



Die Color-Kernsockelleiste ist speziell zum Einkleben von Bodenbelagsstreifen (PVC, CV, Linoleum und Designbeläge) konzipiert. Der elastische Bodenbelag kann in den Sockelleisten fortgeführt werden, wodurch ein harmonischer Übergang zwischen Boden und Wand geschaffen wird. Die Innen- und Außenecken lassen sich exakt und fugenlos umlaufend stanzen und die Montage erfolgt unsichtbar mit Klebeband von UZIN oder dem Döllken Heißschmelzkleber. Die flexible Bodenlippe gewährleistet zudem einen optimalen Bodenabschluss.

Vorteile im Überblick:

- flexible Lippen zu Wand und Boden / kein Nachverfugen notwendig
- interessante optische Wirkung
- große Flexibilität der Sockelleiste
- mit der Stanze fugenlose Außen- und passgenaue Innenecken
- schnelle Verlegung ohne Kappsäge

Haben Sie Fragen zum Produkt oder benötigen Tipps von unseren Profis? Dann kontaktieren Sie uns einfach:
Hotline: +49 3643/ 4170-222
oder über unsere App!

Döllken
Profiles

we create.
we innovate.

SURTECO GROUP

Produktinformationen



Die C 60 life TOP besteht aus einem HDF-Kern, ummantelt mit chlorfreiem Polyblend auf Basis PP/TPE mit flexiblen Weichlippen. Zur Montage empfehlen wir die Verklebung mit dem perfekt auf die Leiste abgestimmten Montageband Toptac 35 von UZIN oder Döllken Heißschmelzkleber.

Die Bodenbelagsstreifen lassen sich mit dem Streifenschneider punktgenau herstellen. PVC und CV-Beläge können mit UZIN Contact 40 eingeklebt werden.

Die Endkappen sind als passendes Zubehör in verschiedenen Farben (weiß, hellbeige, grau, alumetallic, schokoladenbraun, schwarz) erhältlich. Mit den praktischen Anpresseinsätzen lassen sich die Designbelagsstreifen kinderleicht stanzen.

Farben C 60 life TOP

* auch für C 100 life verfügbar



Technische Daten

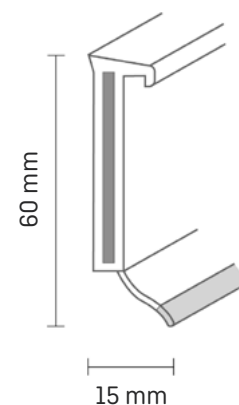

Geeignet für Designbeläge mit einer Materialstärke bis zu 4,5 mm.

1 VE = 20 x 5,15 m

Auf Anfrage als 100 mm Höhe erhältlich!

Verarbeitungsempfehlung



Neue Verarbeitungsvideos auf www.doellken-profiles.com, in der Doellken-App oder auf YouTube.

Döllken Profiles GmbH
Stangenallee 3
99428 Nohra b. Weimar
Follow us on

T: +49 3643 4170 711
F: +49 3643 4170 330
info@doellken-profiles.com
www.doellken-profiles.com

D 60 life TOP



Die Kernsockelleiste ist speziell zum Einkleben von Streifen des Designbodens konzipiert. Das Dekor des Designbelages kann mit der D 60 life Top in der Sockelleiste fortgeführt werden, wodurch ein harmonischer und dekorgleicher Übergang zwischen Boden und Wand geschaffen wird. Die Innen- und Außenecken lassen sich exakt und fugenlos umlaufend stanzen und die Montage erfolgt unsichtbar mit Klebeband von UZIN oder dem Döllken Heißschmelzkleber. Geeignet ist die D 60 für Designbeläge mit einer Materialstärke bis zu 4,5 mm.

Vorteile im Überblick:

- flexible Lippen zu Wand und Boden / kein Nachverfugen notwendig
- mit der Stanze fugenlose Außen- und passgenaue Innenecken
- interessante optische Wirkung
- große Flexibilität der Sockelleiste
- schnelle Verlegung ohne Kappsäge

Haben Sie Fragen zum Produkt oder benötigen Tipps von unseren Profis? Dann kontaktieren Sie uns einfach:
Hotline: +49 3643/ 4170-222
oder über unsere App!

Döllken
Profiles

we create.
we innovate.

SURTECO GROUP

Produktinformationen



Die D 60 life TOP besteht aus einem HDF-Kern, ummantelt mit chlorfreiem Polyblend auf Basis PP/TPE mit flexiblen Weichlippen. Zur Montage empfehlen wir die Verklebung mit dem perfekt auf die Leiste abgestimmten Montageband Toptac 35 von UZIN oder Döllken Heißschmelzkleber.

Die Bodenbelagsstreifen lassen sich mit dem Streifenschneider punktgenau herstellen. PVC und CV-Beläge können mit UZIN Contact 40 eingeklebt werden.

Die Endkappen sind als passendes Zubehör in verschiedenen Farben erhältlich. Mit den praktischen Anpresseinsätzen lassen sich die Designbelagsstreifen kinderleicht stanzen.

Farben C 60 life TOP



* für das Zubehör erhältliche Farben

Technische Daten

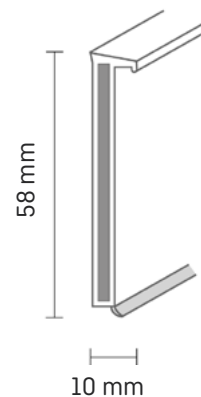

Geeignet für Designbeläge mit einer Materialstärke bis zu 4,5 mm.

1 VE = 20 x 5,15 m

Verarbeitungsempfehlung



Beachten Sie hierzu auch unsere Verarbeitungsanleitung! Zu finden unter: www.doellken-profiles.com oder in der Doellken-App



Neue Verarbeitungsvideos auf www.doellken-profiles.com, in der Doellken-App oder auf YouTube.

Döllken Profiles GmbH
Stangenallee 3
99428 Nohra b. Weimar
Follow us on

T: +49 3643 4170 711
F: +49 3643 4170 330
info@doellken-profiles.com
www.doellken-profiles.com

S 60 flex life TOP

S 100 flex life TOP

Tipps vom Profi

Beachten Sie auch dazu die
Verarbeitungsanleitung und -
videos auf www.doellken-profiles.com,
in der Doellken-App oder auf YouTube.



Die Kernsockelleisten von Döllken Profiles sind einzigartig. Hochwertige Kerne aus FSC-zertifizierten Nadelholzfasern werden mit Hochleistungspolymeren ummantelt, wodurch die Kernsockelleisten sehr robust werden. Die Kernsockelleisten sind besonders umweltfreundlich und verfügen über unterschiedliche Zertifizierungen.

Besonders praktisch und zeitsparend: Sämtliche Kernsockelleisten sind mit Systemwerkzeugen, wie der Döllken-Stanze, professionell zu verarbeiten.

Vorteile im Überblick:

- flexible Lippen zu Wand und Boden
- eine robuste Oberfläche
- große Flexibilität der Sockelleiste
- mit der Stanze fugenlose Außen - und passgenaue Innenecken
- kein Zubehör erforderlich
- kein Dreck und Lärm beim Zuschneiden der Leiste

Haben Sie Fragen zum Produkt oder benötigen Tipps von unseren Profis? Dann kontaktieren Sie uns einfach:
Hotline: +49 3643 4170 222
oder über unsere App!

Döllken
Profiles

we create.
we innovate.

SURTECO GROUP

Produktinformationen



Bestehend aus HDF - Kern, ummantelt mit dem chlorfreien Polyblend auf Basis PP/TPE, mit flexibler Weichlippe unten.



Die Innen- und Außenecken können mit der Döllken-Stanze aus dem Profil gebildet werden. Die Montage erfolgt unsichtbar mit dem Döllken-Heißschmelzkleber.



Passende Abschlüsse mittels dekorangepassten Endkappen und Verbinder sind als Zubehör erhältlich. (1 VE = 10 Stk., lieferbar in 3 Farben (weiß, grau, schwarz))

Großhandel

Farben (Sonderfarben ab 500m möglich)

schneeweiß 1005	weiß* 1013	weißgrau* 1145	lichtgrau* 1012	silbermetallic 1152	grau* 1147	alumetallic 1168	schwarz* 1144
terra 1006	kirschbaum 2372	fruchtbaum 2360	beige* 1148	braun* 1082	hellbeige* 1014	malua 2336	eiche weiß 2629
ahorn 2541	native oak 2570	buche hell* 2542	buche 2543	eiche natur 2544	macoré 2540	kirschbaum alt 2539	teak gebeizt 2371
kirsche grau 2814	nussbaum island 2395	fruchtbaum hell 2336	kirsch country 2361	nussbaum traditional 2587	fruchtbaum dunkel 2363	rustikal graubraun 2362	nussbaum antik 2245
eiche country 2365	eiche klassisch 2339	eiche gedämpft 2329	eiche gebeizt 2357	anthrazit 2718	vintage desert 2571	fashion oak 2572	salsa 2781
smoked oak white 2485	boogie 2780	quartet 2782	azur 1155	mahagoni 2547	eiche hell 2545**		

Technische Daten

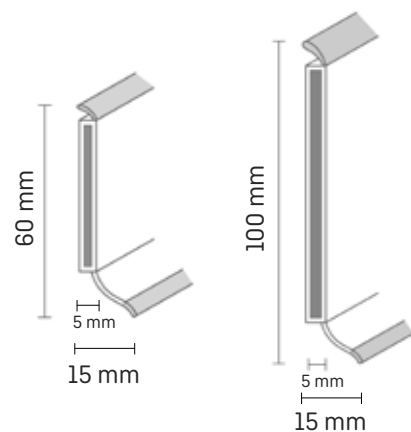

1 VE = 20 x 5,15 m

1 VE = 10 x 5,15 m

Verarbeitungsempfehlungen



* auch für S 100 life verfügbar

**ausschließlich für die S 100 life verfügbar

Döllken Profiles GmbH
Stangenallee 3
99428 Nohra b. Weimar
Follow us on

T: +49 3643 4170 711
F: +49 3643 4170 330
info@doellken-profiles.com
www.doellken-profiles.com

Sicherheitsdatenblatt gemäß Verordnung (EG) Nr. 1907/2006

Erstellt: 15.11.2017
Überarbeitet: 10.04.2026
Version: 05
Ersetzt Version: 04 vom 14.08.2025

Döllken Kernsockelleisten mit HDF-Kern

1. Bezeichnung des Stoffes bzw. der Zubereitung und Firmenbezeichnung

1.1. Bezeichnung des Stoffes / Handelsname:

S60 Flex Life Top, S100 life, Kernsockelleiste 60/80, D60 life TOP, C60 life TOP

1.2 Verwendung:

Sockelleiste für den Abschluß Boden/Wand

1.3. Hersteller:

Döllken Profiles GmbH
Industriestr. 1, 59199 Bönen
Tel.: +49 2383 91000 717
Fax: +49 2383 91000 591
Mail: info@doellken-profiles.com

2. Mögliche Gefahren

2.1 Einstufung:

Kein gefährlicher Stoff oder Gemisch nach Verordnung (EG) Nr. 1272/2008 (CLP).

2.2 Kennzeichnungselemente:

Keine Gefahrenpiktogramme, keine Signalwörter.

2.3 Sonstige Gefahren:

Staub bei Bearbeitung vermeiden. Bei Erhitzen/Zerspanen können Zersetzungsprodukte entstehen (z. B. CO, CO₂).

3. Zusammensetzung / Angaben zu Bestandteilen

3.1 Stoffe:

HDF-Kern ummantelt mit Polypropylen mit Dichtlippen aus TPE

4. Erste-Hilfe-Maßnahmen

4.1 Beschreibung der Erste-Hilfe-Maßnahmen:

nach Einatmen: entfällt
nach Hautkontakt: keine besonderen Maßnahmen erforderlich
nach Augenkontakt: keine besonderen Maßnahmen erforderlich
nach Verschlucken: keine besonderen Maßnahmen erforderlich

4.2 Wichtigste akute und verzögert auftretende Symptome und Wirkungen:

entfällt

Sicherheitsdatenblatt gemäß Verordnung (EG) Nr. 1907/2006

Erstellt: 15.11.2017
Überarbeitet: 10.04.2026
Version: 05
Ersetzt Version: 04 vom 14.08.2025

Döllken Kernsockelleisten mit HDF-Kern

4.3 Hinweise auf ärztliche Soforthilfe oder Spezialbehandlung:
entfällt

5. Maßnahmen zur Brandbekämpfung

5.1 Löschmittel:

geeignet: Wassersprühstrahl, Schaum, Löschpulver
ungeeignet: Wasservollstrahl

5.2 Besondere vom Stoff oder Gemisch ausgehende Gefahren:

gefährliche Brandgase: Kohlenmonoxid, Kohlendioxid, Kohlenstoffpartikel, Rauchentwicklung bei Verbrennung

5.3 Hinweise für die Brandbekämpfung:

Umgebungsluftunabhängiges Atemschutzgerät verwenden und undurchlässige Kleidung und Handschuhe tragen.

6. Maßnahmen bei unbeabsichtigter Freisetzung

6.1 Personenbezogene Vorsichtsmaßnahmen, Schutzausrüstung und in Notfällen anzuwendende Verfahren:

keine besonderen Maßnahmen erforderlich

6.2 Umweltschutzmaßnahmen:

keine besonderen Maßnahmen erforderlich

6.3 Methoden und Material für Rückhaltung und Reinigung:

mechanisch aufnehmen und ordnungsgemäß entsorgen

6.4 Verweis auf andere Abschnitte:

Schutzmaßnahmen unter Abschnitt 7 und 8 beachten.

7. Handhabung und Lagerung

7.1 Schutzmaßnahmen zur sicheren Handhabung:

Handhabung: Staubabsaugung bei Bearbeitung verwenden..

7.2 Bedingungen zur sicheren Lagerung unter Berücksichtigung von Unverträglichkeiten:

Nicht mit brennbaren Stoffen zusammen lagern.
Trocken lagern und von Zündherde fernhalten.
Allgemeine Regeln des vorbeugenden Brandschutzes beachten.

7.3 Spezifische Endanwendungen:

keine Angaben erforderlich

Sicherheitsdatenblatt

gemäß Verordnung (EG) Nr. 1907/2006

Erstellt: 15.11.2017

Überarbeitet: 10.04.2026

Version: 05

Ersetzt Version: 04 vom 14.08.2025

Döllken Kernsockelleisten mit HDF-Kern

8. Begrenzung und Überwachung der Exposition / Persönliche Schutzausrüstung

8.1 Atemschutz:

8.1.1 Grenzwerte für die Exposition am Arbeitsplatz und/oder biologische Grenzwerte Arbeitsplatzgrenzwerte (AGW) Deutschland:

entfällt

8.1.2 DNEL- und PNEC-Werte:

entfällt

8.1.3 Control-Banding (z.B. ILO, EMKG):

Entfällt

8.2 Begrenzung und Überwachung der Exposition:

8.2.1 Geeignete technische Steuerungseinrichtungen:

Bei der mechanischen, spanenden Bearbeitung eine Staubabsaugung anlegen.

8.2.2 Individuelle Schutzmaßnahmen – persönliche Schutzausrüstung:

Augenschutz: falls bei der Bearbeitung Staub anfällt, Schutzbrille mit Seitenschutz tragen

Körperschutz: nicht erforderlich

Handschutz: nicht erforderlich

Atemschutz: falls bei der Bearbeitung Staub anfällt, Staubmaske tragen

8.2.3 Begrenzung und Überwachung der Umweltexposition:

Siehe Abschnitt 6 und 7.

9. Physikalische und chemische Eigenschaften

9.1 Angaben zu den grundlegenden physikalischen und chemischen Eigenschaften:

Aussehen:

-Aggregatzustand:	fest
-Farbe:	verschieden
Geruch:	schwach, charakteristisch
Geruchsschwelle:	nicht bestimmt
pH-Wert:	nicht bestimmt
Schmelzpunkt / Gefrierpunkt:	150 °C (Erweichung) / keine Daten vorhanden
Siedepunkt / Siedebereich:	entfällt
Flammpunkt:	keine Daten vorhanden
Verdampfungsgeschwindigkeit:	keine Daten vorhanden
Entzündbarkeit (fest, gasförmig):	keine Daten vorhanden
obere/untere Entzündbarkeits- oder Explosionsgrenzen:	keine Daten vorhanden
Dampfdruck:	entfällt
Dampfdichte:	keine Daten vorhanden
relative Dichte:	keine Daten vorhanden
Löslichkeit(en):	unlöslich in Wasser bei 20 °C
Verteilungskoeff. n-Oktanol / Wasser:	keine Daten vorhanden

Sicherheitsdatenblatt

gemäß Verordnung (EG) Nr. 1907/2006

Erstellt: 15.11.2017

Überarbeitet: 10.04.2026

Version: 05

Ersetzt Version: 04 vom 14.08.2025

Döllken Kernsockelleisten mit HDF-Kern

Selbstentzündungstemperatur:	keine Daten vorhanden
Zersetzungstemperatur:	keine Daten vorhanden
Viskosität:	keine Daten vorhanden
explosive Eigenschaften:	keine Daten vorhanden
oxidierende Eigenschaften:	bei der thermischen Zersetzung

9.2 Sonstige Angaben:

Weitere physikalisch –chemische Daten wurden nicht ermittelt.

10. Stabilität und Reaktivität

10.1 Reaktivität:

Bei bestimmungsgemäßer Verwendung sind keine gefährlichen Reaktionen bekannt.

10.2 Chemische Stabilität:

Das Produkt ist unter normalen Umgebungsbedingungen (Raumtemperatur) chemisch stabil.

10.3 Möglichkeit gefährlicher Reaktionen:

Bei bestimmungsgemäßer Verwendung sind keine gefährlichen Reaktionen zu erwarten.

10.4 Zu vermeidende Bedingungen:

entfällt

10.5 Unverträgliche Materialien:

entfällt

10.6 Gefährliche Zersetzungsprodukte:

bei der Verbrennung: Chlorwasserstoff, Kohlenmonoxid, Kohlendioxid, Kohlenstoffpartikel

11. Toxikologische Angaben

11.1 Angaben zu toxikologischen Wirkungen:

Nach derzeitigen Kenntnissen und bei sachgerechter Anwendung sind bisher keine schädigenden Auswirkungen bekannt geworden.

12. Umweltbezogene Angaben

12.1 Toxizität:

Bei sachgerechter Anwendung sind bisher keine umweltschädigenden Auswirkungen bekannt geworden.

12.2 Persistenz und Abbaubarkeit:

Das Produkt ist biologisch nicht abbaubar.

12.3 Bioakkumulationspotenzial:

keine Daten vorhanden

Sicherheitsdatenblatt

gemäß Verordnung (EG) Nr. 1907/2006

Erstellt: 15.11.2017

Überarbeitet: 10.04.2026

Version: 05

Ersetzt Version: 04 vom 14.08.2025

Döllken Kernsockelleisten mit HDF-Kern

12.4 Mobilität im Boden:

entfällt

12.5 Ergebnis der PBT- und vPvB-Beurteilung:

keine Daten vorhanden

12.6 Andere schädliche Wirkungen:

keine Daten vorhanden

13. Hinweise zur Entsorgung

13.1 Verfahren der Abfallbehandlung:

Produkt: Kann unter Beachtung der behördlichen Vorschriften einer Verbrennungsanlage zugeführt werden.
Bei der Entsorgung örtliche, behördliche Vorschriften beachten.

Produktverpackung: Pappverpackung kann der Altpapierverwertung zugeführt werden.
Folie kann einer Verwertung oder dem Recycling zugeführt werden.

14. Angaben zum Transport

14.1 UN-Nummer:

keine Daten vorhanden

14.2 Ordnungsgemäße UN-Versandbezeichnung:

ADR / RID: kein Gefahrgut
IMDG-Code / ICAO-Ti / IATA-DGR: kein Gefahrgut

14.3 Transportgefahrenklassen:

kein Gefahrgut

14.4 Verpackungsgruppe:

keine Daten vorhanden

14.5 Umweltgefahren:

Kennzeichen umweltgefährdende Stoffe

ADR/RID / IMDG-Code / ICAO-Ti / IATA-DGR: ja / nein

Marine Pollutant: ja / nein

14.6 Besondere Vorsichtshinweise für den Verwender:

siehe Abschnitte 6 – 8

14.7 Massengutbeförderung gemäß Anhang II des MARPOL-Übereinkommens 73/78 und gemäß IBC-Code:

Verschmutzungskategorie (X, Y oder Z): nicht festgelegt

Sicherheitsdatenblatt gemäß Verordnung (EG) Nr. 1907/2006

Erstellt: 15.11.2017
Überarbeitet: 10.04.2026
Version: 05
Ersetzt Version: 04 vom 14.08.2025

Döllken Kernsockelleisten mit HDF-Kern

Schiffstyp [1, 2 oder 3]: nicht festgelegt

15. Rechtsvorschriften

15.1 Vorschriften zu Sicherheit, Gesundheits- und Umweltschutz / spezifische Rechtsvorschriften für den Stoff oder das Gemisch:

Nach den vorliegenden Daten kein gefährlicher Stoff.

15.2 Stoffsicherheitsbeurteilung:

Das Produkt wurde keiner Sicherheitsbeurteilung unterzogen.

16. Sonstige Angaben

Die Angaben stützen sich auf den heutigen Stand der Kenntnisse sowie Erfahrungen und basieren auf den Angaben unserer Rohstoff-Lieferanten. Das Sicherheitsdatenblatt beschreibt Produkte im Hinblick auf Sicherheitserfordernisse. Die Angaben haben nicht die Bedeutung der Zusicherung von Eigenschaften. Diese Version ersetzt alle vorherigen.

Legende:

ADR:	Europäisches Übereinkommen über die internationale Beförderung gefährlicher Güter auf der Straße
BImSchV:	Verordnung zur Durchführung des Bundes-Immissionsschutzgesetzes
CAS:	C hemical A bstracts S ervice
EC:	Effektive Konzentration
IATA-DGR:	I nternational A ir T ransport A ssociation- D angerous G oods R egulations
IBC -Code:	Internationaler Code für den Bau und die Ausrüstung von Schiffen zur Beförderung gefährlicher Chemikalien
ICAO-TI:	I nternational C ivil A viation O rganization- T echnical I nstructions
IMDG-Code:	International M aritime C ode for D angerous G oods
IUCLID:	I nternational U niform C hemical I nformation D atabase
LC:	Letale Konzentration
LD:	Letale D osis
log Kow:	Verteilungskoeffizient zwischen Oktanol und Wasser
MARPOL:	M aritime P ollution C onvention
OECD:	O rganisation for E conomic C o-operation and D evelopment
PBT:	P ersistent, b iakkumulierbar, t oxisch
RID:	Ordnung für die internationale Eisenbahnbeförderung gefährlicher Güter
TRGS:	T echnische R egeln für G efährstoffe
VOC:	V olatile O rganic C ompounds (flüchtige organische Verbindungen)
vPvB:	sehr persistent und sehr bioakkumulierbar
VwVwS:	V erwaltungsvorschrift w assergefährdender S toffe
WGK:	W assergefährdungsklasse

Environmental Product Declaration

EPD of multiple products, based on the worst case product in accordance with ISO 14025:2006 and EN 15804:2012+A2:2019/AC:2021 for:

Core Skirting Boards with HDF core

from

Döllken Profiles

SURTECO GROUP

Programme:	The International EPD® System, www.environdec.com
Programme operator:	EPD International AB
EPD registration number:	EPD-IES-0005772
Publication date:	2025-07-01
Valid until:	2030-06-20

An EPD should provide current information and may be updated if conditions change. The stated validity is therefore subject to the continued registration and publication at www.environdec.com

General information

Programme information

Programme: The International EPD® System
EPD International AB
Address: Box 210 60
SE-100 31 Stockholm
Sweden
Website: www.environdec.com
E-mail: info@environdec.com

Accountabilities for PCR, LCA and independent, third-party verification

Product Category Rules (PCR)

CEN standard EN 15804 serves as the Core Product Category Rules (PCR)

Product Category Rules (PCR): 2019:14 Construction Products PCR 2019:14 version 1.3.4

PCR review was conducted by: Martin Erlandsson, IVL Swedish Environmental Research Institute, contact via: Martin.Erlandsson@ivl.se

Life Cycle Assessment (LCA)

LCA accountability:



ecosy GmbH
Neubrucker Straße, Gebäude 9928
55768 Hoppstädten-Weiersbach
Germany

Office: +49 6782 172819
Web: www.eco-sy.com

Third-party verification

Independent third-party verification of the declaration and data, according to ISO 14025:2006, via:

EPD verification by individual verifier

Third-party verifier:

Dr. Andreas Ciroth
Alt-Moabit 130-131
10557 Berlin
Germany

Approved by: The International EPD[®] System

Procedure for follow-up of data during EPD validity involves third party verifier:

Yes No

The EPD owner has the sole ownership, liability, and responsibility for the EPD.

EPDs within the same product category but registered in different EPD programmes, or not compliant with EN 15804, may not be comparable. For two EPDs to be comparable, they must be based on the same PCR (including the same version number) or be based on fully-aligned PCRs or versions of PCRs; cover products with identical functions, technical performances and use (e.g. identical declared/functional units); have equivalent system boundaries and descriptions of data; apply equivalent data quality requirements, methods of data collection, and allocation methods; apply identical cut-off rules and impact assessment methods (including the same version of characterisation factors); have equivalent content declarations; and be valid at the time of comparison. For further information about comparability, see EN 15804 and ISO 14025.

EPDs of construction products may not be comparable if they do not comply with EN 15804+A2.

Company information

Owner of the EPD

Döllken Profiles GmbH
Industriestraße 1
59199 Bönen
Germany

Contact

Martin Ottow
Head of Material Development
martin.ottow@Döllken-profiles.com



Description of the organisation

Döllken Profiles as part of Surteco Group

The trend-setting Group structure of SURTECO GROUP SE reflects the vision of the perfect decor network: SURTECO GROUP SE offers its customers multifaceted, multifunctional and professional solutions from a single source.

Sustainability at Döllken Profiles GmbH

As a globally thinking and acting company, we at Döllken Profiles GmbH always strive to provide the best performance in terms of quality and service, taking into account environmental and energy-relevant aspects in all our areas of activity and influence.

We see it as our duty to protect the environment, to conserve resources and to avoid or continuously minimise environmental pollution wherever possible in the course of our actions, and we are aware of the influence of our actions and our products, also on the quality of life of future generations. In this way, we also want to make our contribution to stopping climate change and maintaining biodiversity and ecosystems. More information on the Sustainable Development Goals and the contribution to the goals of the United Nations can be found here: [SURTECO - Sustainability](#)

Döllken Profiles as expert for skirting and profile solutions

For more than 60 years Döllken have been experts in the design, development and manufacture at different production sites within Germany of high quality plastic extruded profiles. Although our services are primarily intended for companies operating within the industrial sector, our capabilities and expertise enables us to support on all aspects of design and innovation led projects, supplying quality products to customers spanning multiple market sectors and many diverse applications on a global scale.



Management system-related certifications

All production sites are certificated as follows:

- ISO 9001:2015 - Quality Management
- ISO 14001:2015 - Environment Management
- ISO 50001:2011 - Energy Management

Name and location of production site

Production site: Bönen
Industriestraße 1
59199 Bönen, Germany

Product information

Product name

Core Skirting Board with HDF core.

This EPD includes all variants of core skirting boards with HDF core. An overview can be found in the appendix to the EPD.

Product description

The core skirting boards consist of HDF board which are coated with high-performance polymers.

The core skirtings are characterised by the following features:

- HDF cores made from certified softwood fibres
- Robust and durable due to sheathing with high-performance polymers
- Quick installation, as all core skirtings are punchable
- TCF (totally chlorinefree)

Application

Core skirtings are suitable to every floor covering. They can be installed in no time at all and create a harmonious connection between wall and floor. Döllken core skirting boards are available in a wide range of colours and decors and are based on the most popular floor coverings.

Properties of the core skirting boards:

- Different sizes and colours/decors, depending on the variant
- With or without flexible soft lip at the top or/and bottom

Installation/Processing

The core skirting boards get glued on a wall.

Further laying instructions are available on: <https://www.doellken-profiles.com/en/processing>

Product Stewardship

All core skirting boards are free of harmful plasticisers in accordance with the REACH regulation. Döllken core skirtings are particularly environmentally friendly and have certifications, e.g. most of our core skirting boards are certified with the Greenguard Gold Standard and Blauer Engel (Blue Angel, Germany).

UN CPC code

CPC 31442: Hardboard

Geographical scope

The EPD covers the geographical scope of production in Germany as well as the distribution and disposal of the packaged products within the EU including the United Kingdom and Northern Ireland.

LCA information

Functional unit / declared unit

One (1) linear meter of a core skirting board with HDF core incl. package with a weight of 0.437 kg.

Worst-case product for EPD: TS 100 life Top

The worst case product including all variants as shown in the appendix.

Reference service life

RSL is 20 years.

The service life corresponds to an equivalent floor covering and, with proper care, does not need to be renewed before the floor covering.

Time representativeness

2023

Database(s) and LCA software used

- Software: openLCA, v2.3
- Database: ecoinvent v3.9.1 EN15804

Description of system boundaries

Cradle to gate with options, modules C1–C4, module D and with optional modules (A1–A3 + C + D and additional modules).

Infrastructure is included in the background database, with the exception of transportation, energy generation and waste treatment, for which the infrastructure processes were excluded.

All processes have been included in the LCA, with exception of the infrastructure processes mentioned above.

Module A1-3

The module includes the machining processes from cradle to factory gate. This includes:

- provision of product and packaging specific materials
- transportation of materials to factory
- energy consumption of production processes, its emissions and waste generation

Module A4

Transportation of the packaged goods to customers via a generic distance of 100 km by lorry (>32 metric ton, EURO6).

Module A5

Disposal of product packaging (collection rate: 100%) including transportation of 50 km to waste incineration by lorry (>32 metric ton, EURO6) and product installation on the construction sites via hot melt adhesive.

Module C1

During the dismantling of the product from the building, there is no effort that has to be taken into account as part of the life cycle assessment.

Module C2

Transport to waste treatment at the end of product life via a generic distance of 50 km by lorry (>32 metric ton, EURO6).

Module C3

The product is incinerated in a waste-to-energy plant (collection rate: 95%).

Module C4

Disposal of slag and ash from the incineration of the product originating from module C3.

Module D

Benefits and loads beyond the system boundaries resulting from waste treatment of

- module A3 (production waste),
- module A5 (packaging waste),
- module C3 (end of product life)

The diagram shows the input and output material & energy flows per module.

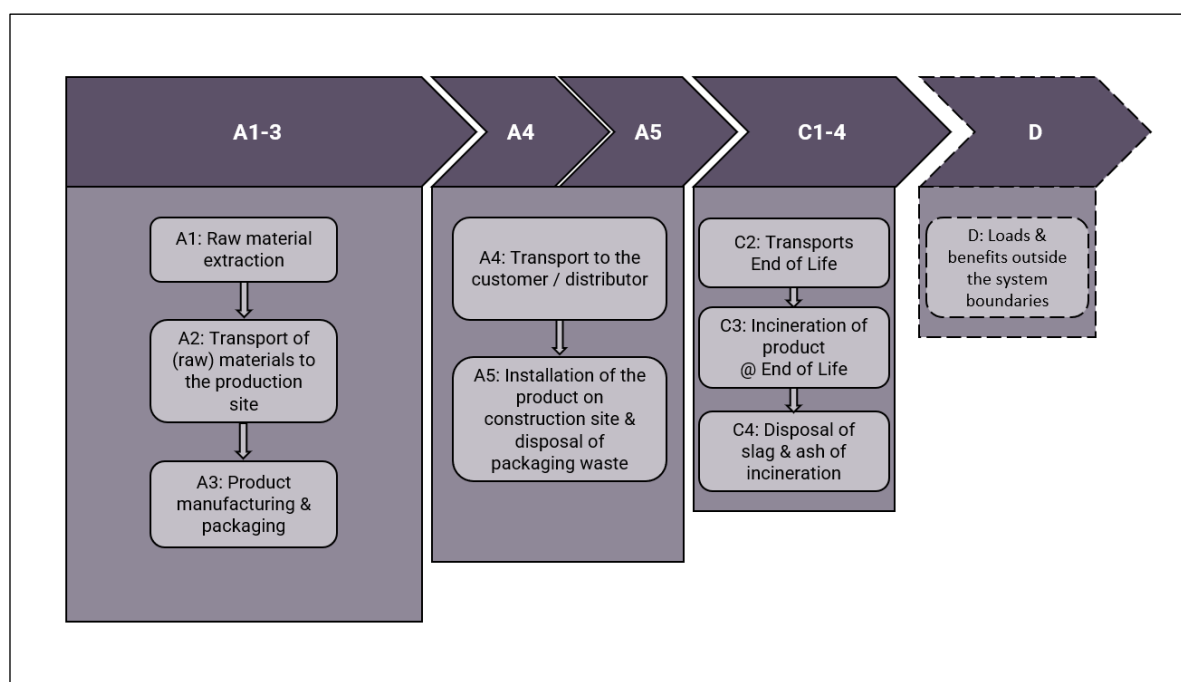

Electricity mix

A data set for electricity generation from hydropower, Norway, from ecoinvent 3.9.1 with an emission factor of 0.006 kg CO₂/kWh was used. The electricity was purchased via guarantees of origin within the EU. The data set used represents in a good quality the electricity consumed by DOELLKEN PROFILES in 2023 as well as previous and future years.

Cut-off rules

Wherever possible, all data collected from the recipe and the bill of materials for the packaging material were taken into account. Thus, material flows with a mass fraction of less than one per-cent were also accounted for with exclusion of:

- a few packaging materials (0.1 mass-%)
- water consumption of a closed-loop water cooling system
- energy consumption of the internal transport and storage system

If generic data sets from the ecoinvent database are not available in the current version, they have been modelled in-house. Individual substances for which no data sets are available:

- substituted by substances with similar environmental effects, or
- if not possible, have been cut-off.

Allocation

The disposal of production waste (module A1-3) is subject to a fee. Therefore, it is not considered as a co-product. Thus, instead of economic a mass allocation was made.

Credits resulting from the thermal recovery of packaging waste (module A5) as well as from energy recovery or recycling in the end of life (module C3) are assigned to module D.

Allocations in the LCA datasets used follow the cut-off rules and are documented online. The database ecoinvent v3.9.1 EN 15804 was used. It can be assumed that the cut-off rules are consistent in the context of the requirements of EN 15804.

Data quality

The data used come from the manufacturer's data collection from the production year 2023. In addition to primary production data, necessary background data of the raw materials used were specifically modelled or come from the ecoinvent database for EN 15804 studies. Mixtures, energy inputs and waste generation of additives and other precursors not included in the ecoinvent database and for which suppliers are unable to provide information were estimated conservatively.

The manufacturer's production data were collected from recipes and bill of materials, production data were measured or calculated on the basis of an average annual value.

Overall, a good data quality can be assumed, the representativeness can be classified as very good.

Comparability

In principle, a comparison or evaluation of EPD data is only possible if all data sets to be compared have been created in accordance with EN 15804 and the building context or the product-specific performance characteristics are taken into account.

Modules declared, geographical scope, share of specific data (in GWP-GHG results) and data variation (in GWP-GHG results)

	Product stage			Construction process stage		Use stage						End of life stage				Resource recovery stage	
	Raw material supply	Transport	Manufacturing	Transport	Construction installation	Use	Maintenance	Repair	Replacement	Refurbishment	Operational energy use	Operational water use	De-construction demolition	Transport	Waste processing	Disposal	Reuse-Recovery-Recycling-potential
Module	A1	A2	A3	A4	A5	B1	B2	B3	B4	B5	B6	B7	C1	C2	C3	C4	D
Modules declared	X	X	X	X	X	ND	ND	ND	ND	ND	ND	ND	X	X	X	X	X
Geography	EU	EU	DE	EU	EU	-	-	-	-	-	-	-	EU	EU	EU	EU	EU
Specific data used	> 95 %					-	-	-	-	-	-	-	-	-	-	-	-
Variation – products	179 %					-	-	-	-	-	-	-	-	-	-	-	-
Variation – sites	0 %					-	-	-	-	-	-	-	-	-	-	-	-

Disclaimer: The results of module A1-3 are not to be used without considering the results of C modules.

Due to the different variants and their maximum deviation of 179%, it can be assumed that the individual results for all environmental indicators in the comparison of the analysed worst case to the best case product are more than -10%.

Manufacturing

The following graphic gives an overview of the manufacturing process at plant Bönen, Germany.

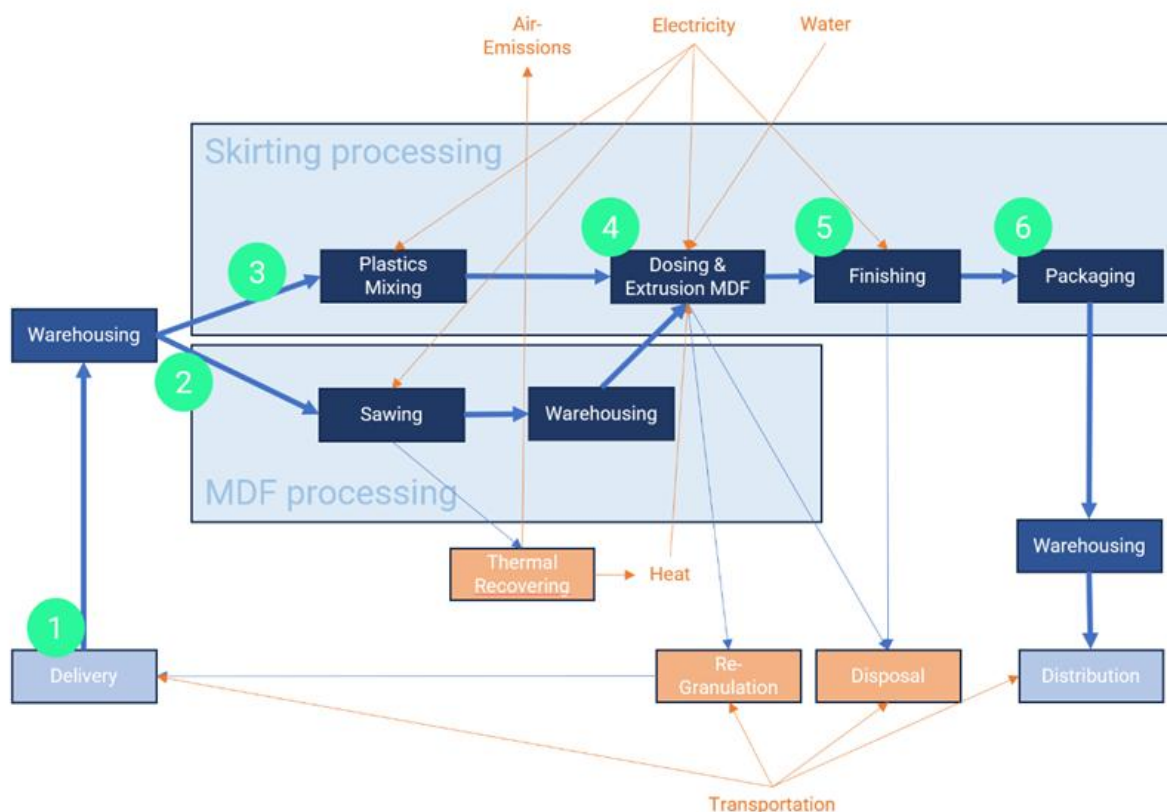

Production of core skirting boards as follows:

1. Delivery of materials and warehousing.
2. Cutting the HDF board to the size of the skirting board and storing the semi-finished products. The wood waste is fed into an internal incinerator with heat recovery.
3. Mixing of the plastic compound for the polyblend and the soft lips.
4. Seamless wrapping of the HDF core with the polyblend and production of the soft lips to seal the skirting board against the wall and floor.
The waste produced during commissioning is shredded in a granulator and fed directly to the extruder. Production waste that is contaminated and cannot be recycled is collected and sent for external recycling.
5. Printed variants are finished with water-based lacquers. Some colored skirting boards are provided with a protective film.
6. The finished products are packed in cardboard boxes.

The finished packaged goods are temporarily stored and then prepared for transport to the customer.

Content information

Product components	Weight, kg	Post-consumer material, weight-%	Biogenic material, weight-% and kg C/declared unit
CSB, total	0.290	0	66.5%; 0.120
Packaging materials	Weight, kg	Weight-% (versus the product)	Weight biogenic carbon, kg C/declared unit
Cardboard	0.022	5%	0.007
Dangerous substances from the candidate list of SVHC for Authorisation	EC No.	CAS No.	Weight-% per functional or declared unit
N/A	-/-	-/-	-/-

Results of the environmental performance indicators

Mandatory impact category indicators according to EN 15804

The characterization factors according to EN15804+A2 were used for the impact assessment. These correspond to the European characterization model according to the Environmental Footprint Method in version 3.1.

The following estimated impact results are only relative statements, which do not indicate the endpoints of the impact categories, exceeding threshold values, safety margins and/or risks.

Results per 1 running meter of Core Skirting Boards with HDF core									
Indicator	Unit	A1-A3	A4	A5	C1	C2	C3	C4	D
GWP-fossil	kg CO2 eq.	6,45E-01	3,35E-03	5,62E-02	0,00E+00	1,65E-03	3,67E-01	1,08E-05	-8,95E-01
GWP-biogenic	kg CO2 eq.	-5,74E-01	9,99E-07	3,02E-02	0,00E+00	4,93E-07	5,99E-01	9,43E-08	-7,15E-04
GWP-luluc	kg CO2 eq.	6,18E-03	2,00E-07	5,77E-03	0,00E+00	9,88E-08	3,85E-06	2,18E-09	-1,10E-04
GWP-total	kg CO2 eq.	7,70E-02	3,36E-03	9,22E-02	0,00E+00	1,65E-03	9,66E-01	1,09E-05	-8,96E-01
ODP	kg CFC 11 eq.	6,47E-09	7,48E-11	1,06E-09	0,00E+00	3,69E-11	1,05E-09	1,77E-13	-4,03E-08
AP	mol H+ eq.	3,69E-03	4,58E-06	2,03E-04	0,00E+00	2,26E-06	2,04E-04	9,32E-08	-7,55E-04
EP-freshwater	kg P eq.	3,36E-04	4,39E-08	6,96E-05	0,00E+00	2,17E-08	1,45E-06	1,90E-07	-2,85E-05
EP-marine	kg N eq.	7,54E-04	1,15E-06	7,87E-05	0,00E+00	5,65E-07	1,22E-04	4,26E-08	-2,57E-04
EP-terrestrial	mol N eq.	7,55E-03	1,12E-05	5,05E-04	0,00E+00	5,50E-06	1,03E-03	4,63E-07	-2,77E-03
POCP	kg NMVOC eq.	2,85E-03	8,38E-06	1,84E-04	0,00E+00	4,13E-06	2,53E-04	1,39E-07	-1,63E-03
ADP-minerals&metals*	kg Sb eq.	1,84E-06	5,48E-10	2,86E-07	0,00E+00	2,70E-10	4,81E-08	6,21E-12	-4,49E-07
ADP-fossil*	MJ	1,26E+01	4,64E-02	1,36E+00	0,00E+00	2,29E-02	1,23E-01	1,44E-04	-1,36E+01
WDP*	m3	2,96E-01	6,34E-05	5,20E-02	0,00E+00	3,12E-05	6,48E-02	5,36E-07	-2,94E-02
Acronyms	GWP-fossil = Global Warming Potential fossil fuels; GWP-biogenic = Global Warming Potential biogenic; GWP-luluc = Global Warming Potential land use and land use change; ODP = Depletion potential of the stratospheric ozone layer; AP = Acidification potential, Accumulated Exceedance; EP-freshwater = Eutrophication potential, fraction of nutrients reaching freshwater end compartment; EP-marine = Eutrophication potential, fraction of nutrients reaching marine end compartment; EP-terrestrial = Eutrophication potential, Accumulated Exceedance; POCP = Formation potential of tropospheric ozone; ADP-minerals&metals = Abiotic depletion potential for non-fossil resources; ADP-fossil = Abiotic depletion for fossil resources potential; WDP = Water (user) deprivation potential, deprivation-weighted water consumption								

*** Disclaimer: The results of this environmental impact indicator shall be used with care as the uncertainties of these results are high or as there is limited experience with the indicator.**

Additional mandatory and voluntary impact category indicators

Results per 1 running meter of Core Skirting Boards with HDF core									
Indicator	Unit	A1-A3	A4	A5	C1	C2	C3	C4	D
GWP-GHG ¹	kg CO ₂ eq.	6,51E-01	3,35E-03	6,20E-02	0,00E+00	1,65E-03	2,66E-01	1,08E-05	-8,95E-01
Additional voluntary indicators e.g. the voluntary indicators from EN 15804 or the global indicators according to ISO 21930:2017									

¹ This indicator accounts for all greenhouse gases except biogenic carbon dioxide uptake and emissions and biogenic carbon stored in the product. As such, the indicator is identical to GWP-total except that the CF for biogenic CO₂ is set to zero.

Resource use indicators

Results per 1 running meter of Core Skirting Boards with HDF core									
Indicator	Unit	A1-A3	A4	A5	C1	C2	C3	C4	D
PERE	MJ	8,94E+00	1,64E-04	1,94E-01	0,00E+00	8,11E-05	7,26E-03	1,42E-05	-1,25E-01
PERM	MJ	7,37E+00	0,00E+00	0,00E+00	0,00E+00	0,00E+00	0,00E+00	0,00E+00	0,00E+00
PERT	MJ	1,63E+01	1,64E-04	1,94E-01	0,00E+00	8,11E-05	7,26E-03	1,42E-05	-1,25E-01
PENRE	MJ	1,26E+01	4,21E-02	1,24E+00	0,00E+00	2,07E-02	1,17E-01	1,31E-04	-1,30E+01
PENRM	MJ	1,12E+00	4,34E-03	1,32E-01	0,00E+00	2,14E-03	6,18E-03	1,30E-05	-6,47E-01
PENRT	MJ	1,37E+01	4,64E-02	1,37E+00	0,00E+00	2,29E-02	1,23E-01	1,44E-04	-1,36E+01
SM	kg	9,88E-02	1,16E-05	1,80E-03	0,00E+00	5,71E-06	2,72E-04	1,69E-07	-8,04E-03
RSF	MJ	4,11E-02	4,08E-06	6,48E-04	0,00E+00	2,01E-06	1,13E-04	6,19E-08	-3,47E-03
NRSF	MJ	3,15E-02	7,25E-06	1,09E-03	0,00E+00	3,57E-06	2,48E-04	3,48E-08	-4,21E-03
FW	m ³	-2,73E-02	1,48E-06	1,07E-03	0,00E+00	7,29E-07	1,10E-03	1,15E-08	-7,54E-04
Acronyms	PERE = Use of renewable primary energy excluding renewable primary energy resources used as raw materials; PERM = Use of renewable primary energy resources used as raw materials; PERT = Total use of renewable primary energy resources; PENRE = Use of non-renewable primary energy excluding non-renewable primary energy resources used as raw materials; PENRM = Use of non-renewable primary energy resources used as raw materials; PENRT = Total use of non-renewable primary energy resources; SM = Use of secondary material; RSF = Use of renewable secondary fuels; NRSF = Use of non-renewable secondary fuels; FW = Use of net fresh water								

Waste indicators

Results per 1 running meter of Core Skirting Boards with HDF core									
Indicator	Unit	A1-A3	A4	A5	C1	C2	C3	C4	D
Hazardous waste disposed	kg	1,39E-05	3,08E-07	3,77E-06	0,00E+00	1,52E-07	4,85E-07	9,40E-10	-5,67E-05
Non-hazardous waste disposed	kg	3,99E-02	1,68E-05	3,44E-03	0,00E+00	8,26E-06	1,13E-02	1,95E-06	-1,41E-02
Radioactive waste disposed	kg	1,52E-05	4,57E-09	7,19E-07	0,00E+00	2,25E-09	1,08E-07	3,07E-11	-3,58E-06

Output flow indicators

Results per 1 running meter of Core Skirting Boards with HDF core									
Indicator	Unit	A1-A3	A4	A5	C1	C2	C3	C4	D
Components for re-use	kg	0,00E+00	0,00E+00	0,00E+00	0,00E+00	0,00E+00	0,00E+00	0,00E+00	0,00E+00
Material for recycling	kg	0,00E+00	0,00E+00	0,00E+00	0,00E+00	0,00E+00	0,00E+00	0,00E+00	0,00E+00
Materials for energy recovery	kg	7,35E-02	0,00E+00	1,62E-03	0,00E+00	0,00E+00	2,05E-03	1,52E-07	0,00E+00
Exported energy, electricity	MJ	0,00E+00	0,00E+00	0,00E+00	0,00E+00	0,00E+00	0,00E+00	0,00E+00	0,00E+00
Exported energy, thermal	MJ	0,00E+00	0,00E+00	0,00E+00	0,00E+00	0,00E+00	0,00E+00	0,00E+00	0,00E+00

References

ecoinvent v3.9.1

Documentation of changes implemented in the ecoinvent database v3.9.1 (2022.12.15).

EN 15804:2022-03

Sustainability of construction works - Environmental product declarations - Core rules for the product category of construction products (EN 15804:2012 + A2:2019 + AC:2021).

General Programme Instructions (GPI) for the International EPD[®] System

Version 5.0, EPD International (2024-06-19).

ISO 14025:2011-10

Environmental labels and declarations - Type III environmental declarations - Principles and procedures (ISO 14025:2011).

ISO 14040:2021-02

Environmental management - Life cycle assessment - Principles and Framework (ISO 14040:2006 + Amd 1:2020).

ISO 14044:2021-02

Environmental management - Life cycle assessment - Requirements and guidelines (ISO 14044:2006 + Amd 1:2017 + Amd 2:2020)

openLCA

Comprehensive User Manual, GreenDelta GmbH (February 2020).

Product Category Rules (PCR)

PCR 2019:14 Construction products (EN 15804+A2), Version 1.3.4, EPD International (2023-04-30).

Appendix

Overview of the product variants with HDF core (as at: 2024):

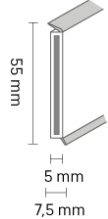
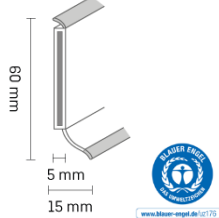
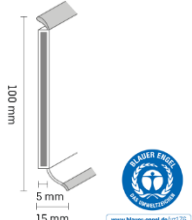
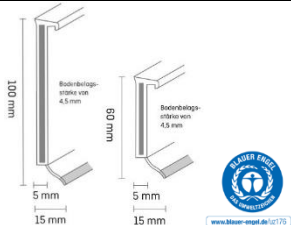
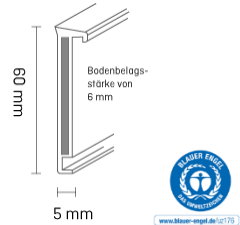
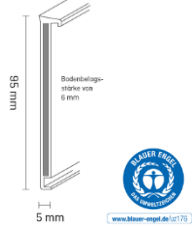
Product	Cross section	Surface	Lips	Height [mm]	Packaging unit
S 60 flex life		6 different colours	Flexible soft lip at the top and bottom	55	20 x 5.15 m
S 60 flex life Top		60 different variants (decors & colours)	Flexible soft lip at the top and bottom	60	20 x 5.15 m
S 100 life		9 different variants (decors & colours)	Flexible soft lip at the top and bottom	100	10 x 2.5 m
C 100 life / C 60 life Top		15 different variants (decors & colours)	Flexible soft lip at the bottom	60, 100	20 x 5.15 m
TS 60 life Top		10 different colours	without	60	20 x 5.15 m
TS 100 life Top		2 different colours	without	95	10 x 5.15 m

Product	Cross section	Surface	Lips	Heigh [mm]	Packaging unit
Carpet Skirting board 60		5 different colours	without	60	20 x 5.15 m

For further information visit: www.doellken-profiles.com/en/products/solidcore-skirtings

Döllken Profiles GmbH
Industriestraße 1
59199 Bönen
T: +49 3643 4170 711
F: +49 3643 4170 330
info@doellken-profiles.com
www.doellken-profiles.com



www.environdec.com

KUNDENINFORMATION

Kontakt: Martin Ottow
T : +49 2383 910 00 583
martin.ottow@doellken-profiles.com
Datum: 10.04.2026

Inhaltsstoffe Kernsockelleisten

Sehr geehrter Kunde,

unsere Kernsockelleisten sind aus chlorfreiem Kunststoff gefertigt und besonders emissionsarm und es werden keine schädlichen organischen Verbindungen an die Innenraumlufte abgegeben.

Eine Vielzahl unserer Kernsockelleisten ist mit dem Blauen Engel und nach dem Greenguard Gold Standard für die besondere Umweltfreundlichkeit ausgezeichnet.

Bezüglich unserer Informationspflicht gemäß Art. 33 der REACH-VO über den Einsatz von besonders besorgniserregenden Stoffen (SVHC) können wir Ihnen mitteilen, dass in unseren gefertigten Profilen keine Stoffe der ECHA-Kandidatenliste (Aktualisierungsstand: 25.06.2025), die oberhalb der geforderten Grenzkonzentration liegen, enthalten sind.

Für die Kerne werden FSC-, bzw. PEFC-zertifizierte Holzwerkstoffe verwendet, bei denen mindestens 70% Holz aus nachhaltiger Forstwirtschaft im Holzanteil eingesetzt werden.
Die Dichtlippen sind aus TPE gefertigt.

Für Rückfragen stehen wir Ihnen jederzeit gerne zur Verfügung.

Mit freundlichen Grüßen
Döllken-Profiles GmbH

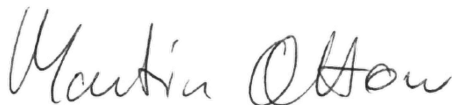

i.V. Martin Ottow

Hauptsitz
Döllken Profiles GmbH
Industriestr. 1
59199 Bönen
HRB Hamm 98 96
USt-ID. DE150105409
WEEE-Reg.-Nr. DE 41380720

Kontakt
Telefon: +49 2383 910 00-717
Fax: +49 2383 910 00-591
E-Mail: info@doellken-profiles.com
E-Mail (Bereich Baemarkt):
kundencenter@praktikus.de
www.doellken-profiles.com

Geschäftsführung
Martina Baden
Reinhold Affhüppe

Bankverbindungen
Deutsche Bank AG, Weimar
BIC: DEUT DE 8E 820
IBAN: DE61 8207 0000 0282 2898 00
Commerzbank AG, Weimar
BIC: COBA DE FF 822
IBAN: DE34 8204 0000 0456 9695 00

Certificate of Compliance

Certificate

65504-420

Issue Date

31 Dec 2014

Expiration Date

28 Dec 2026



Ranee Valles
Director and General Manager

UL Verification Services Inc.
2211 Newmarket Parkway, ste 106
Marietta, GA 30067 USA

UL Verification Services does hereby certify that an independent assessment has been conducted on behalf of:

Döllken Profiles GmbH

for the following product:

S 60 flex life Top

The product has been evaluated and meets the requirements for:

GREENGUARD Gold

UL 2818 - 2022 Gold Standard for Chemical Emissions for Building Materials, Finishes and Furnishings

Building products and interior finishes are determined compliant in accordance with California Department of Public Health (CDPH) Standard Method V1.2-2017 using an Office and Classroom Environment.



UL Solutions evaluated representative samples of the identified product, process or facility to the identified Standard or other requirements in accordance with the agreements and any applicable program service terms in place between UL Solutions and the Client (collectively "Agreement"). The Client is authorized to use the UL Mark for the identified Product, process or facility covered by this certificate, in accordance with the terms of the Agreement. This Certificate is valid for the identified dates unless there is non-compliance with the Agreement. This certificate is subject to modification, suspension and withdrawal by UL Solutions see SPOT.ul.com, to authenticate the certificate.

Certificate of Compliance

GREENGUARD Gold Certification Criteria for Building Products and Interior Finishes

Criteria	CAS Number	Maximum Allowable Predicted Concentration	Units
TVOC ^(A)	-	0.22	mg/m ³
Formaldehyde	50-00-0	9 (7.3 ppb)	µg/m ³
Total Aldehydes ^(B)	-	0.043	ppm
4-Phenylcyclohexene	4994-16-5	6.5	µg/m ³
Particle Matter less than 10 µm ^(C)	-	20	µg/m ³
1-Methyl-2-pyrrolidinone ^(D)	872-50-4	160	µg/m ³
Individual VOCs ^(E)	-	1/2 CREL or 1/100th TLV	-

- (A) Defined to be the total response of measured VOCs falling within the C₆ – C₁₆ range, with responses calibrated to a toluene surrogate. Maximum allowable predicted TVOC concentrations for GREENGUARD Gold (0.22 mg/m³) fall in the range of 0.5 mg/m³ or less, as specified in CDPH Standard Method v1.2.
- (B) The sum of all measured normal aldehydes from formaldehyde through nonanal, plus benzaldehyde, individually calibrated to a compound specific standard. Heptanal through nonanal are measured via TD/GC/MS analysis and the remaining aldehydes are measured using HPLC/UV analysis.
- (C) Particle emission requirement only applicable to HVAC Duct Products with exposed surface area in air streams (a forced air test with specific test method) and for wood finishing (sanding) systems.
- (D) Based on the CA Prop 65 Maximum Allowable Dose Level for inhalation of 3,200 µg/day and an inhalation rate of 20 m³/day
- (E) Allowable levels for chemicals not listed are derived from the lower of 1/2 the California Office of Environmental Health Hazard Assessment (OEHHA) Chronic Reference Exposure Level (CREL) as required per the CDPH/EHLB/Standard Method v1.2 and BIFMA level credit 7.6.2 and 1/100th of the Threshold Limit Value (TLV) industrial work place standard (Reference: American Conference of Government Industrial Hygienists, 6500 Glenway, Building D-7, and Cincinnati, OH 45211-4438).



UL Solutions evaluated representative samples of the identified product, process or facility to the identified Standard or other requirements in accordance with the agreements and any applicable program service terms in place between UL Solutions and the Client (collectively "Agreement"). The Client is authorized to use the UL Mark for the identified Product, process or facility covered by this certificate, in accordance with the terms of the Agreement. This Certificate is valid for the identified dates unless there is non-compliance with the Agreement. This certificate is subject to modification, suspension and withdrawal by UL Solutions see SPOT.ul.com, to authenticate the certificate.

Certificate of Compliance

Certificate

65505-420

Issue Date

31 Dec 2014

Expiration Date

28 Dec 2026



Rane Valles
Director and General Manager

UL Verification Services Inc.
2211 Newmarket Parkway, ste 106
Marietta, GA 30067 USA

UL Verification Services does hereby certify that an independent assessment has been conducted on behalf of:

Döllken Profiles GmbH

for the following product:

S 100 life

The product has been evaluated and meets the requirements for:

GREENGUARD Gold

UL 2818 - 2022 Gold Standard for Chemical Emissions for Building Materials, Finishes and Furnishings

Building products and interior finishes are determined compliant in accordance with California Department of Public Health (CDPH) Standard Method V1.2-2017 using an Office and Classroom Environment.



UL Solutions evaluated representative samples of the identified product, process or facility to the identified Standard or other requirements in accordance with the agreements and any applicable program service terms in place between UL Solutions and the Client (collectively "Agreement"). The Client is authorized to use the UL Mark for the identified Product, process or facility covered by this certificate, in accordance with the terms of the Agreement. This Certificate is valid for the identified dates unless there is non-compliance with the Agreement. This certificate is subject to modification, suspension and withdrawal by UL Solutions see SPOT.ul.com, to authenticate the certificate.

Certificate of Compliance

GREENGUARD Gold Certification Criteria for Building Products and Interior Finishes

Criteria	CAS Number	Maximum Allowable Predicted Concentration	Units
TVOC ^(A)	-	0.22	mg/m ³
Formaldehyde	50-00-0	9 (7.3 ppb)	µg/m ³
Total Aldehydes ^(B)	-	0.043	ppm
4-Phenylcyclohexene	4994-16-5	6.5	µg/m ³
Particle Matter less than 10 µm ^(C)	-	20	µg/m ³
1-Methyl-2-pyrrolidinone ^(D)	872-50-4	160	µg/m ³
Individual VOCs ^(E)	-	1/2 CREL or 1/100th TLV	-

- (A) Defined to be the total response of measured VOCs falling within the C₆ – C₁₆ range, with responses calibrated to a toluene surrogate. Maximum allowable predicted TVOC concentrations for GREENGUARD Gold (0.22 mg/m³) fall in the range of 0.5 mg/m³ or less, as specified in CDPH Standard Method v1.2.
- (B) The sum of all measured normal aldehydes from formaldehyde through nonanal, plus benzaldehyde, individually calibrated to a compound specific standard. Heptanal through nonanal are measured via TD/GC/MS analysis and the remaining aldehydes are measured using HPLC/UV analysis.
- (C) Particle emission requirement only applicable to HVAC Duct Products with exposed surface area in air streams (a forced air test with specific test method) and for wood finishing (sanding) systems.
- (D) Based on the CA Prop 65 Maximum Allowable Dose Level for inhalation of 3,200 µg/day and an inhalation rate of 20 m³/day
- (E) Allowable levels for chemicals not listed are derived from the lower of 1/2 the California Office of Environmental Health Hazard Assessment (OEHHA) Chronic Reference Exposure Level (CREL) as required per the CDPH/EHLB/Standard Method v1.2 and BIFMA level credit 7.6.2 and 1/100th of the Threshold Limit Value (TLV) industrial work place standard (Reference: American Conference of Government Industrial Hygienists, 6500 Glenway, Building D-7, and Cincinnati, OH 45211-4438).



UL Solutions evaluated representative samples of the identified product, process or facility to the identified Standard or other requirements in accordance with the agreements and any applicable program service terms in place between UL Solutions and the Client (collectively "Agreement"). The Client is authorized to use the UL Mark for the identified Product, process or facility covered by this certificate, in accordance with the terms of the Agreement. This Certificate is valid for the identified dates unless there is non-compliance with the Agreement. This certificate is subject to modification, suspension and withdrawal by UL Solutions see SPOT.ul.com, to authenticate the certificate.

Certificate of Compliance

Certificate

65509-420

Issue Date

31 Dec 2014

Expiration Date

28 Dec 2026



Ranee Valles
Director and General Manager

UL Verification Services Inc.
2211 Newmarket Parkway, ste 106
Marietta, GA 30067 USA

UL Verification Services does hereby certify that an independent assessment has been conducted on behalf of:

Döllken Profiles GmbH

for the following product:

D 60 life Top

The product has been evaluated and meets the requirements for:

GREENGUARD Gold

UL 2818 - 2022 Gold Standard for Chemical Emissions for Building Materials, Finishes and Furnishings

Building products and interior finishes are determined compliant in accordance with California Department of Public Health (CDPH) Standard Method V1.2-2017 using an Office and Classroom Environment.



UL Solutions evaluated representative samples of the identified product, process or facility to the identified Standard or other requirements in accordance with the agreements and any applicable program service terms in place between UL Solutions and the Client (collectively "Agreement"). The Client is authorized to use the UL Mark for the identified Product, process or facility covered by this certificate, in accordance with the terms of the Agreement. This Certificate is valid for the identified dates unless there is non-compliance with the Agreement. This certificate is subject to modification, suspension and withdrawal by UL Solutions see SPOT.ul.com, to authenticate the certificate.

Certificate of Compliance

GREENGUARD Gold Certification Criteria for Building Products and Interior Finishes

Criteria	CAS Number	Maximum Allowable Predicted Concentration	Units
TVOC ^(A)	-	0.22	mg/m ³
Formaldehyde	50-00-0	9 (7.3 ppb)	µg/m ³
Total Aldehydes ^(B)	-	0.043	ppm
4-Phenylcyclohexene	4994-16-5	6.5	µg/m ³
Particle Matter less than 10 µm ^(C)	-	20	µg/m ³
1-Methyl-2-pyrrolidinone ^(D)	872-50-4	160	µg/m ³
Individual VOCs ^(E)	-	1/2 CREL or 1/100th TLV	-

- (A) Defined to be the total response of measured VOCs falling within the C₆ – C₁₆ range, with responses calibrated to a toluene surrogate. Maximum allowable predicted TVOC concentrations for GREENGUARD Gold (0.22 mg/m³) fall in the range of 0.5 mg/m³ or less, as specified in CDPH Standard Method v1.2.
- (B) The sum of all measured normal aldehydes from formaldehyde through nonanal, plus benzaldehyde, individually calibrated to a compound specific standard. Heptanal through nonanal are measured via TD/GC/MS analysis and the remaining aldehydes are measured using HPLC/UV analysis.
- (C) Particle emission requirement only applicable to HVAC Duct Products with exposed surface area in air streams (a forced air test with specific test method) and for wood finishing (sanding) systems.
- (D) Based on the CA Prop 65 Maximum Allowable Dose Level for inhalation of 3,200 µg/day and an inhalation rate of 20 m³/day
- (E) Allowable levels for chemicals not listed are derived from the lower of 1/2 the California Office of Environmental Health Hazard Assessment (OEHHA) Chronic Reference Exposure Level (CREL) as required per the CDPH/EHLB/Standard Method v1.2 and BIFMA level credit 7.6.2 and 1/100th of the Threshold Limit Value (TLV) industrial work place standard (Reference: American Conference of Government Industrial Hygienists, 6500 Glenway, Buildin D-7, and Cincinnati, OH 45211-4438).



UL Solutions evaluated representative samples of the identified product, process or facility to the identified Standard or other requirements in accordance with the agreements and any applicable program service terms in place between UL Solutions and the Client (collectively "Agreement"). The Client is authorized to use the UL Mark for the identified Product, process or facility covered by this certificate, in accordance with the terms of the Agreement. This Certificate is valid for the identified dates unless there is non-compliance with the Agreement. This certificate is subject to modification, suspension and withdrawal by UL Solutions see SPOT.ul.com, to authenticate the certificate.

Certificate of Compliance

Certificate

65504-420

Issue Date

31 Dec 2014

Expiration Date

28 Dec 2026



Rane Valles
Director and General Manager

UL Verification Services Inc.
2211 Newmarket Parkway, ste 106
Marietta, GA 30067 USA

UL Verification Services does hereby certify that an independent assessment has been conducted on behalf of:

Döllken Profiles GmbH

for the following product:

S 60 flex life Top

The product has been evaluated and meets the requirements for:

GREENGUARD Gold

UL 2818 - 2022 Gold Standard for Chemical Emissions for Building Materials, Finishes and Furnishings

Building products and interior finishes are determined compliant in accordance with California Department of Public Health (CDPH) Standard Method V1.2-2017 using an Office and Classroom Environment.



UL Solutions evaluated representative samples of the identified product, process or facility to the identified Standard or other requirements in accordance with the agreements and any applicable program service terms in place between UL Solutions and the Client (collectively "Agreement"). The Client is authorized to use the UL Mark for the identified Product, process or facility covered by this certificate, in accordance with the terms of the Agreement. This Certificate is valid for the identified dates unless there is non-compliance with the Agreement. This certificate is subject to modification, suspension and withdrawal by UL Solutions see SPOT.ul.com, to authenticate the certificate.

Certificate of Compliance

GREENGUARD Gold Certification Criteria for Building Products and Interior Finishes

Criteria	CAS Number	Maximum Allowable Predicted Concentration	Units
TVOC ^(A)	-	0.22	mg/m ³
Formaldehyde	50-00-0	9 (7.3 ppb)	µg/m ³
Total Aldehydes ^(B)	-	0.043	ppm
4-Phenylcyclohexene	4994-16-5	6.5	µg/m ³
Particle Matter less than 10 µm ^(C)	-	20	µg/m ³
1-Methyl-2-pyrrolidinone ^(D)	872-50-4	160	µg/m ³
Individual VOCs ^(E)	-	1/2 CREL or 1/100th TLV	-

- (A) Defined to be the total response of measured VOCs falling within the C₆ – C₁₆ range, with responses calibrated to a toluene surrogate. Maximum allowable predicted TVOC concentrations for GREENGUARD Gold (0.22 mg/m³) fall in the range of 0.5 mg/m³ or less, as specified in CDPH Standard Method v1.2.
- (B) The sum of all measured normal aldehydes from formaldehyde through nonanal, plus benzaldehyde, individually calibrated to a compound specific standard. Heptanal through nonanal are measured via TD/GC/MS analysis and the remaining aldehydes are measured using HPLC/UV analysis.
- (C) Particle emission requirement only applicable to HVAC Duct Products with exposed surface area in air streams (a forced air test with specific test method) and for wood finishing (sanding) systems.
- (D) Based on the CA Prop 65 Maximum Allowable Dose Level for inhalation of 3,200 µg/day and an inhalation rate of 20 m³/day
- (E) Allowable levels for chemicals not listed are derived from the lower of 1/2 the California Office of Environmental Health Hazard Assessment (OEHHA) Chronic Reference Exposure Level (CREL) as required per the CDPH/EHLB/Standard Method v1.2 and BIFMA level credit 7.6.2 and 1/100th of the Threshold Limit Value (TLV) industrial work place standard (Reference: American Conference of Government Industrial Hygienists, 6500 Glenway, Buildin D-7, and Cincinnati, OH 45211-4438).



UL Solutions evaluated representative samples of the identified product, process or facility to the identified Standard or other requirements in accordance with the agreements and any applicable program service terms in place between UL Solutions and the Client (collectively "Agreement"). The Client is authorized to use the UL Mark for the identified Product, process or facility covered by this certificate, in accordance with the terms of the Agreement. This Certificate is valid for the identified dates unless there is non-compliance with the Agreement. This certificate is subject to modification, suspension and withdrawal by UL Solutions see SPOT.ul.com, to authenticate the certificate.

Certificate of Compliance

Certificate

65510-420

Issue Date

31 Dec 2014

Expiration Date

28 Dec 2026



Ranee Valles
Director and General Manager

UL Verification Services Inc.
2211 Newmarket Parkway, ste 106
Marietta, GA 30067 USA

UL Verification Services does hereby certify that an independent assessment has been conducted on behalf of:

Döllken Profiles GmbH

for the following product:

C 60 life Top

The product has been evaluated and meets the requirements for:

GREENGUARD Gold

UL 2818 - 2022 Gold Standard for Chemical Emissions for Building Materials, Finishes and Furnishings

Building products and interior finishes are determined compliant in accordance with California Department of Public Health (CDPH) Standard Method V1.2-2017 using an Office and Classroom Environment.



UL Solutions evaluated representative samples of the identified product, process or facility to the identified Standard or other requirements in accordance with the agreements and any applicable program service terms in place between UL Solutions and the Client (collectively "Agreement"). The Client is authorized to use the UL Mark for the identified Product, process or facility covered by this certificate, in accordance with the terms of the Agreement. This Certificate is valid for the identified dates unless there is non-compliance with the Agreement. This certificate is subject to modification, suspension and withdrawal by UL Solutions see SPOT.ul.com, to authenticate the certificate.

Certificate of Compliance

GREENGUARD Gold Certification Criteria for Building Products and Interior Finishes

Criteria	CAS Number	Maximum Allowable Predicted Concentration	Units
TVOC ^(A)	-	0.22	mg/m ³
Formaldehyde	50-00-0	9 (7.3 ppb)	µg/m ³
Total Aldehydes ^(B)	-	0.043	ppm
4-Phenylcyclohexene	4994-16-5	6.5	µg/m ³
Particle Matter less than 10 µm ^(C)	-	20	µg/m ³
1-Methyl-2-pyrrolidinone ^(D)	872-50-4	160	µg/m ³
Individual VOCs ^(E)	-	1/2 CREL or 1/100th TLV	-

- (A) Defined to be the total response of measured VOCs falling within the C₆ – C₁₆ range, with responses calibrated to a toluene surrogate. Maximum allowable predicted TVOC concentrations for GREENGUARD Gold (0.22 mg/m³) fall in the range of 0.5 mg/m³ or less, as specified in CDPH Standard Method v1.2.
- (B) The sum of all measured normal aldehydes from formaldehyde through nonanal, plus benzaldehyde, individually calibrated to a compound specific standard. Heptanal through nonanal are measured via TD/GC/MS analysis and the remaining aldehydes are measured using HPLC/UV analysis.
- (C) Particle emission requirement only applicable to HVAC Duct Products with exposed surface area in air streams (a forced air test with specific test method) and for wood finishing (sanding) systems.
- (D) Based on the CA Prop 65 Maximum Allowable Dose Level for inhalation of 3,200 µg/day and an inhalation rate of 20 m³/day
- (E) Allowable levels for chemicals not listed are derived from the lower of 1/2 the California Office of Environmental Health Hazard Assessment (OEHHA) Chronic Reference Exposure Level (CREL) as required per the CDPH/EHLB/Standard Method v1.2 and BIFMA level credit 7.6.2 and 1/100th of the Threshold Limit Value (TLV) industrial work place standard (Reference: American Conference of Government Industrial Hygienists, 6500 Glenway, Building D-7, and Cincinnati, OH 45211-4438).



UL Solutions evaluated representative samples of the identified product, process or facility to the identified Standard or other requirements in accordance with the agreements and any applicable program service terms in place between UL Solutions and the Client (collectively "Agreement"). The Client is authorized to use the UL Mark for the identified Product, process or facility covered by this certificate, in accordance with the terms of the Agreement. This Certificate is valid for the identified dates unless there is non-compliance with the Agreement. This certificate is subject to modification, suspension and withdrawal by UL Solutions see SPOT.ul.com, to authenticate the certificate.

Certificate of Compliance

Certificate

65506-420

Issue Date

31 Dec 2014

Expiration Date

28 Dec 2026



Rane Valles
Director and General Manager

UL Verification Services Inc.
2211 Newmarket Parkway, ste 106
Marietta, GA 30067 USA

UL Verification Services does hereby certify that an independent assessment has been conducted on behalf of:

Döllken Profiles GmbH

for the following product:

S 40/22 flex life

The product has been evaluated and meets the requirements for:

GREENGUARD Gold

UL 2818 - 2022 Gold Standard for Chemical Emissions for Building Materials, Finishes and Furnishings

Building products and interior finishes are determined compliant in accordance with California Department of Public Health (CDPH) Standard Method V1.2-2017 using an Office and Classroom Environment.



UL Solutions evaluated representative samples of the identified product, process or facility to the identified Standard or other requirements in accordance with the agreements and any applicable program service terms in place between UL Solutions and the Client (collectively "Agreement"). The Client is authorized to use the UL Mark for the identified Product, process or facility covered by this certificate, in accordance with the terms of the Agreement. This Certificate is valid for the identified dates unless there is non-compliance with the Agreement. This certificate is subject to modification, suspension and withdrawal by UL Solutions see SPOT.ul.com, to authenticate the certificate.

Certificate of Compliance

GREENGUARD Gold Certification Criteria for Building Products and Interior Finishes

Criteria	CAS Number	Maximum Allowable Predicted Concentration	Units
TVOC ^(A)	-	0.22	mg/m ³
Formaldehyde	50-00-0	9 (7.3 ppb)	µg/m ³
Total Aldehydes ^(B)	-	0.043	ppm
4-Phenylcyclohexene	4994-16-5	6.5	µg/m ³
Particle Matter less than 10 µm ^(C)	-	20	µg/m ³
1-Methyl-2-pyrrolidinone ^(D)	872-50-4	160	µg/m ³
Individual VOCs ^(E)	-	1/2 CREL or 1/100th TLV	-

- (A) Defined to be the total response of measured VOCs falling within the C₆ – C₁₆ range, with responses calibrated to a toluene surrogate. Maximum allowable predicted TVOC concentrations for GREENGUARD Gold (0.22 mg/m³) fall in the range of 0.5 mg/m³ or less, as specified in CDPH Standard Method v1.2.
- (B) The sum of all measured normal aldehydes from formaldehyde through nonanal, plus benzaldehyde, individually calibrated to a compound specific standard. Heptanal through nonanal are measured via TD/GC/MS analysis and the remaining aldehydes are measured using HPLC/UV analysis.
- (C) Particle emission requirement only applicable to HVAC Duct Products with exposed surface area in air streams (a forced air test with specific test method) and for wood finishing (sanding) systems.
- (D) Based on the CA Prop 65 Maximum Allowable Dose Level for inhalation of 3,200 µg/day and an inhalation rate of 20 m³/day
- (E) Allowable levels for chemicals not listed are derived from the lower of 1/2 the California Office of Environmental Health Hazard Assessment (OEHHA) Chronic Reference Exposure Level (CREL) as required per the CDPH/EHLB/Standard Method v1.2 and BIFMA level credit 7.6.2 and 1/100th of the Threshold Limit Value (TLV) industrial work place standard (Reference: American Conference of Government Industrial Hygienists, 6500 Glenway, Building D-7, and Cincinnati, OH 45211-4438).



UL Solutions evaluated representative samples of the identified product, process or facility to the identified Standard or other requirements in accordance with the agreements and any applicable program service terms in place between UL Solutions and the Client (collectively "Agreement"). The Client is authorized to use the UL Mark for the identified Product, process or facility covered by this certificate, in accordance with the terms of the Agreement. This Certificate is valid for the identified dates unless there is non-compliance with the Agreement. This certificate is subject to modification, suspension and withdrawal by UL Solutions see SPOT.ul.com, to authenticate the certificate.

URKUNDE

Döllken Profiles GmbH
59199 Bönen, Deutschland

wird aufgrund des Zeichenbenutzungsvertrages Nr. 34942 zur DE-UZ 176
Ausgabe 2013 das Recht verliehen, für das Produkt

Döllken Profiles Kernsockelleisten,
Ausführungen gemäß Anhang zum Vertrag

das nachstehend abgebildete Umweltzeichen als Ausweis für die besondere
Umweltfreundlichkeit zu führen.



Bonn, den 07. September 2020

R. Wollmann

Geschäftsführer
RAL gGmbH



Simply Excellent.

RAL gemeinnützige GmbH
Fränkische Straße 7
53229 Bonn - Germany

Anhang zum Vertrag: Döllken Profiles Kernsockelleisten, Ausführungen gemäß Anhang zum Vertrag (Stand: 22.11.2024)

Kernsockelleisten mit MDF- oder HDF-Kern und Ummantelung auf Polyblend Basis PP/TPE

Klassische Profile

S 60 flex life TOP

S 60 flex life mit kurzer Weichlippe

S 100 life Top

S 66/22 flex life

Kernsockelleiste 60

Kernsockelleiste 80

EP 60 flex life

EP 80 flex life

Teppichkernleisten

TS 60 life Top

Teppichkernleiste 60

TS 100 life Top

Cubu Profile

Cubu structured

Cubu flex life Decor

Cubu flex life 40

Cubu flex life 60

Cubu flex life 60 ohne Weichlippe

Cubu flex life 80

Cubu flex life 100

Cubu Decor 60

Cubu Touch & Style 60

Cubu flex life XL 60

Cubu flex life XL 80

Cubu XL Touch & Style 60

Hamburger (Berliner) Profile

Hamburger Stil 60

Hamburger Stil 80

Hamburger Stil 80 slim

Hamburger Stil 100

Einklebeleisten

D 60 life Top

D 55 life Top

C 60 life Top

C 100 life Top

CV-Einklebeleiste 60

Türrahmenprofile

Türrahmenprofil 60

Türrahmenprofil XL